

Physics 125: Classical Physics A

1 Practice Problems for Final Exam

Problem 1

The Space Shuttle flies with a typical altitude of 300 km above the surface of the earth. The radius of earth is 6328 km and the mass of earth is 6×10^{24} kg.

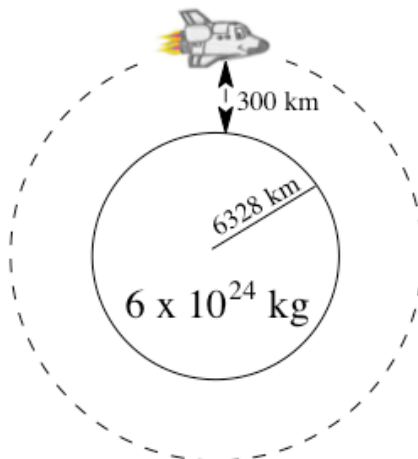

Not to Scale :)

- What is the velocity of the shuttle?
- What is the period of the shuttle's orbit?

Problem 2

Shown in the figure below is a four blade propeller. Each blade has a mass of 5 kg and a length of 3 meters. The propeller starts from rest and reaches 200 RPM after 20 seconds.

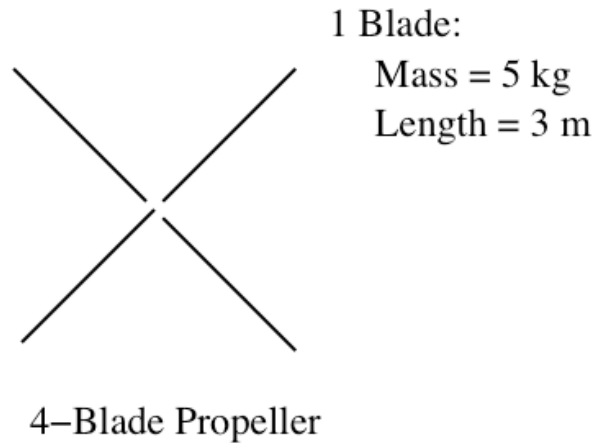

- What is the angular acceleration of the propeller in $\frac{rad}{sec}$?
- How many turns has the propeller undergone in these 20 seconds?
- The speed of sound in air is $345 \frac{m}{s}$. At what ω does the tip of the propeller exceed the speed of sound?
- Assuming the angular acceleration is constant at what time does the tip of the propeller exceed the speed of sound?
- Approximate the propeller as four rods rotating about their ends. What is the moment of inertia, I , of the propeller?
- What torque is required to make the propeller move as detailed in this problem?

Problem 3

A uniform bar of mass $M = 2.5 \text{ kg}$ and length $L = 2\text{m}$ is supported in static equilibrium in a horizontal position by a pin at its left end attached to the wall, and a string attached at the right end which makes an angle relative to the bar of $\theta = 35^\circ$.

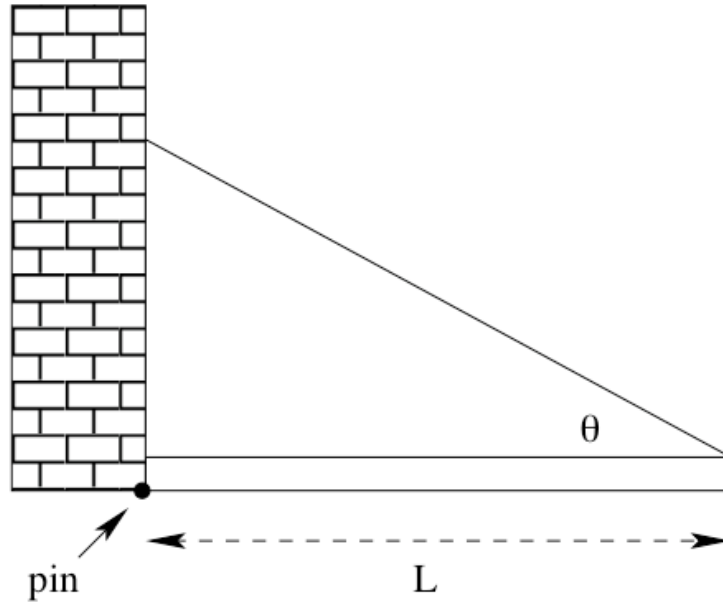

- Find the tension in the string.
- The string breaks and the bar pivots around the pin with no friction. What is its initial angular acceleration, α , just after the string breaks? (The moment of inertia of a uniform bar about an axis through its center is $I = \frac{1}{12}ML^2$ and about an axis through one end is $I = \frac{1}{3}ML^2$).

Problem 4

Shown in the figure below is a grindstone (mass = 80 kg, radius = 0.7 m) that is used to sharpen an axe. The axe is pressed against the spinning grindstone with a normal force of 20 N. When this is done the grindstone slows from an initial motion of 100 rpm and comes to a stop in 2 minutes.

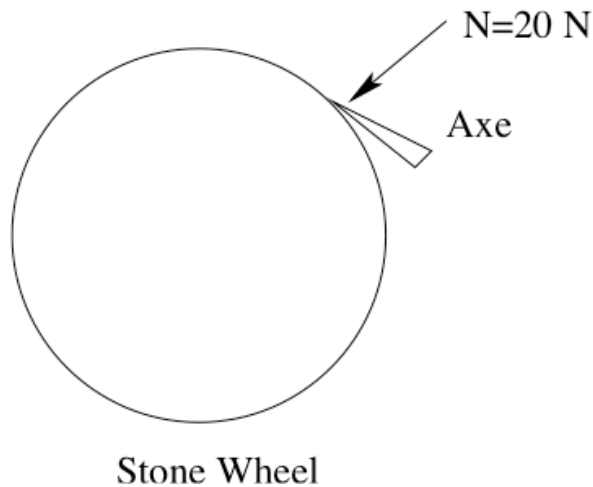

- What is the angular acceleration of the grindstone?
- How many turns does the grindstone make before coming to rest?
- What is the moment of inertia of the grindstone?
- What is the coefficient of kinetic friction between the axe and the grindstone?

Problem 5

Shown in the figure below is a simple yoyo. The string is wrapped around the outside of the yoyo and the yoyo accelerates downward.

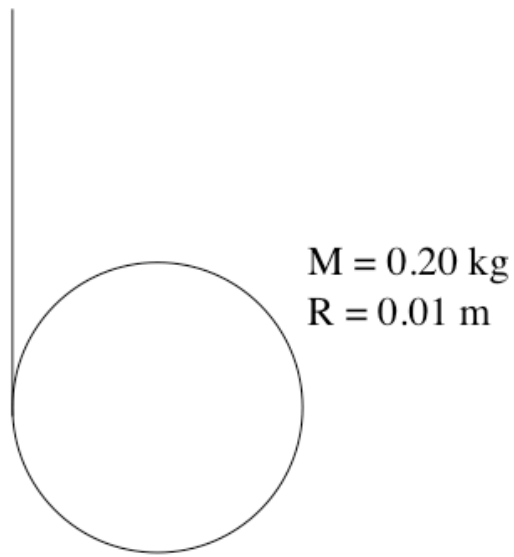

- (a) What is the acceleration of the yoyo?
- (b) What is the tension in the string?

Problem 6

Shown in the figure below is a system of masses and pulleys. NOTE: The pulley has mass and so the tensions on the two sides of the pulley are not the same! Please approximate the pulley as a solid cylinder.

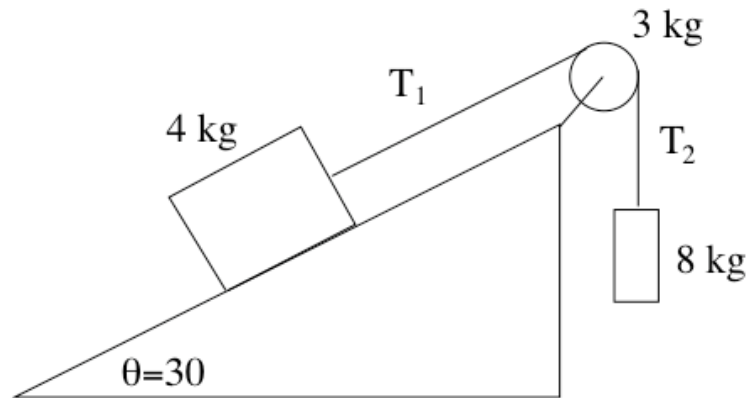

- (a) What is the linear acceleration of the system?
- (b) What is the tension T_1 ?
- (c) What is the tension T_2 ?

Problem 7

10. A race between two cylinders is performed. Both cylinders begin at the top of the 1.5 m tall ramp and roll without slipping to the bottom.



- What is the speed of the hollow cylinder when it reaches the flat?
- What is the speed of the solid cylinder when it reaches the flat?
- Which one would win the race?

Problem 8

You are lowering a bucket into a well. When the bucket is 4 m above the water, your hand slips and the bucket falls toward the water while unwinding the spindle.

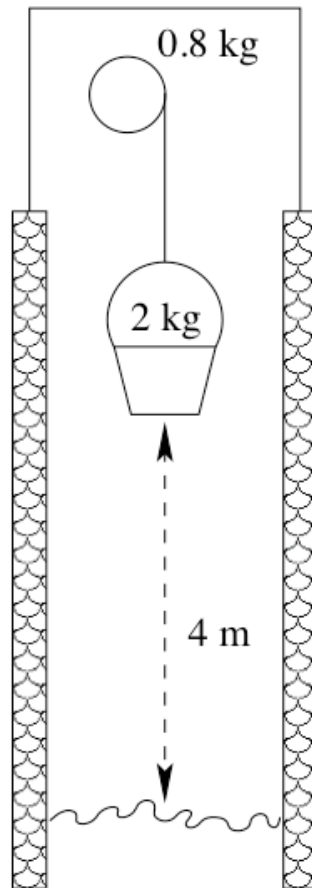

- (a) What is the speed of the bucket when it reaches the water?

Problem 9

You are in lab and see in front of you a hollow cylinder spinning with $\omega = 20$ rpm. You decide to drop the solid cylinder on top of it.

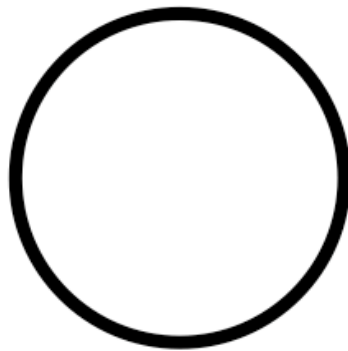

Hollow Cylinder
 $M = 1.5$ kg

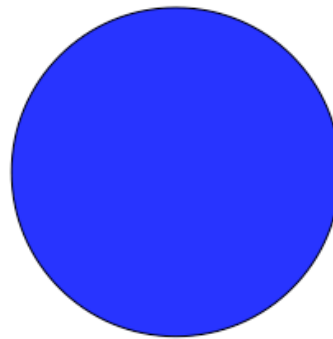

Solid Cylinder
 $M = 2$ kg

- (a) What is the final ω after you drop the solid disk?

Problem 10

You are standing at the end of a diving board as shown in the figure below.

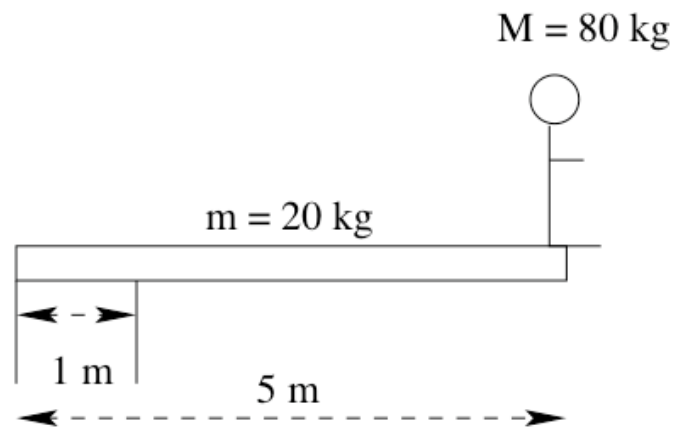

- (a) What is the force from the “center” support?
- (b) What is the force from the left-most support?

Problem 11

Three small blocks, each with mass m , are clamped at the ends and at the center of a massless rod of length L . (The rod is massless, do you think you need to include the moment of inertia of the rod?)

- (a) Compute the moment of inertia of the system about an axis perpendicular to the rod and passing through a point $1/4$ of the length from one end.
- (b) Compute the moment of inertia of the system about an axis perpendicular to the rod and passing through the center of the rod using the "parallel axis theorem" for moment of inertia.
- (c) Check that your answer is correct by explicitly calculating the moment of inertia about the axis in (b)